

# FIREMAGIC®

## POWER BURNER

### INSTALLATION AND OPERATING INSTRUCTIONS

**INSTALLER:** Leave these instructions with consumer.  
**CONSUMER:** Retain for future reference.



**Important:** READ THESE INSTRUCTIONS CAREFULLY BEFORE STARTING INSTALLATION

### SAFETY WARNINGS & CODES

#### **⚠ DANGER**

##### **IF YOU SMELL GAS:**

1. Shut off the gas to the appliance.
2. Extinguish any open flame.
3. Open lid.
4. If odor continues, keep away from the appliance, and **immediately** call your gas supplier or fire department.

**CODE AND SUPPLY REQUIREMENTS:** This power burner must be installed in accordance with local codes and ordinances, or, in the absence of local codes, with either the latest *National Fuel Gas Code (ANSI Z223.1/NFPA 54)*, and *Natural Gas and Propane Storage and Handling Installation Code (CSA-B149.1)*.

This appliance and its individual shutoff valves must be disconnected from the gas supply piping system when testing the system at pressures in excess of ½ psig (3.5 kPa).

This appliance must be isolated from the gas supply piping system by closing its individual manual shutoff valves during any pressure testing of the gas supply system at pressures up to and including ½ psig (3.5 kPa).

**Certified to:** ANSI Z21.58-2007  
CSA 1.6-2007

#### **⚠ WARNING**

1. Do not store or use gasoline or other flammable vapors and liquids in the vicinity of this or any other appliance.
2. A propane cylinder not connected for use shall not be stored in the vicinity of this or any other appliance.

#### **WARNING**

Improper installation, adjustment, alteration, service, or maintenance can cause injury or property damage. Refer to this manual. For assistance or additional information consult a qualified professional installer, service agency, or the gas supplier.

All electrical outlets in the vicinity of the power burner must be properly grounded in accordance with local codes or, in the absence of local codes, with the **National Electrical Code, ANSI/NFPA 70, or the Canadian Electrical Code, CSA C22.1**, whichever is applicable.

Keep all electrical supply cords and fuel supply hoses away from any heated surface.



09-41

Robert H. Peterson Co. • 14724 East Proctor Avenue, • City of Industry, CA 91746

**INSTALLATION INSTRUCTIONS ET MANUEL DU PROPRIÉTAIRE  
POWER BURNER****⚠ DANGER:****SI VOUS SENTEZ LE GAZ :**

1. Coupez l'admission de gaz de l'appareil.
2. Éteindre toute flamme nue.
3. Ouvrir le couvercle.
4. Si l'odeur persiste, éloignez-vous de l'appareil et appelez immédiatement le fournisseur de gaz ou le service d'incendie.

**⚠ AVERTISSEMENT:**

1. Ne stockez pas ou n'employez pas l'essence ou d'autres vapeurs et liquides inflammables à proximité de ceci ou d'aucun autre appareil.
2. Un cylindre de propane non relié pour l'usage ne sera pas stocké à proximité de ceci ou d'aucun autre appareil.

**CONDITIONS DE CODE ET D'APPROVISIONNEMENT:**

Ce gril doit être installé selon des codes et des ordonnances locaux, ou, en l'absence des codes locaux, avec l'un ou l'autre le plus défunt *Code national de gaz de carburant* (norme ANSI Z223.1/NFPA 54), et *Stockage de gaz naturel et de propane et manipulation du code d'installation* (CSA-B149.1).

Cet appareil et ses différents robinets d'isolement doivent être démontés du gaz-fournissent le système sifflant en examinant le système aux pressions au-dessus du ½ psig (kPa 3.5).

Cet appareil doit être isolé dans gaz-fournissent le système sifflant par fermeture que ses différents robinets d'isolement manuels pendant tous les essais sous pression du gaz-fournissent le système aux pressions jusques et y compris le ½ psig (kPa 3.5).

- Ce gril est pour utilisation à l'extérieur seulement. Si l'appareil est entreposé à l'intérieur, enlever les bouteilles et les laisser à l'extérieur.
- Ne pas ranger le gril immédiatement après l'avoir utilisé. le laisser refroidir avant de le déplacer ou de la ranger. Le non respect de cette mesure de sécurité pourrait entraîner un incendie causant des dommages à la propriété, des blessures ou la mort.
- Ne pas utiliser cet appareil sous une surface combustible.
- Ne pas utiliser cet appareil sous un auvent. Le non respect de cette mesure de sécurité pourrait entraîner un incendie ou des blessures.
- Dégagement minimal entre les parois latérales et l'arrière de l'appareil et la construction combustible (45.7 cm à partir des parois latérales et 45.7cm à partir de l'arrière).
- Le régulateur de pression de gaz prévu avec cet appareil de cuisson à gaz pour l'extérieur doit être utilisé. Ce régulateur est réglé pour une pression de sortie de 5 pouces de colonne de l'eau pour le gaz naturel, et 10 pouces pour le propane.
- LE RÉGULATEUR INCLUS D'APPAREILS EST ÉVALUÉ POUR LE MAXIMUM DE 1/2 (LIVRES PAR POUCE CARRÉ). SI VOTRE OFFRE DE GAZ EST 1/2 PLUS GRAND QUE (LIVRES PAR POUCE CARRÉ), UN RÉGULATEUR ADDITIONNEL DOIT ÊTRE INSTALLÉ AVANT LE GRIL. VOIR LA SECTION DE CONDITIONS

**⚠ AVERTISSEMENT:**

L'installation inexacte, l'ajustement, le changement, le service, ou l'entretien peuvent causer des dommages ou des dégâts matériels. Réferez-vous à ce manuel. Pour l'aide ou l'information additionnelle, consultez un installateur professionnel qualifié, l'agence de service, ou le fournisseur de gaz.

Toutes les sorties électriques à proximité du gril doivent être correctement fondues selon des codes locaux, ou en l'absence de local code, avec le code électrique national, ANSI/NFPA 70, ou le code électrique canadien, CSA C22.1, celui qui est applicable.

Maintenez tout électrique-fournissent des cordes et carburant-fournissent des tuyaux partis de n'importe quelle surface de chauffage.

**D'OFFRE DE GAZ POUR LA PRESSON APPROPRIÉE  
D'OFFRE DE GAZ.**

- Ne couvrez jamais la surface entière de cuisine ou de gril de gauffreuses ou de casseroles. La surchauffe se produira et les brûleurs ne seront pas très performants quand la chaleur de combustion est emprisonnée au-dessous de la surface à cuire.
- Ne pulvérisez jamais l'eau sur une unité chaude de gaz, comme ceci peut endommager des composants de porcelaine ou de fer de fonte.
- Une fuite de GPL peut causer un incendie ou une explosion si enflammée entraînant des blessures corporelles graves ou la mort.
- Communiquez avec le fournisseur de GPL pour les réparations ou pour disposer de qules bouteille ou du

**Certifié à la norme: ANSI Z21.58-2007  
CSA 1.6-2007**

**INSTALLATEUR : Laissez ces instructions avec le consommateur.  
CONSOMMATEUR : Maintenez pour la future référence.**

# TABLE OF CONTENTS

PRODUCT DATA TABLE	3
PARTS LIST	4
PLANNING FOR INSTALLATION OF YOUR POWER BURNER	5
WHERE TO INSTALL THE POWER BURNER	5
GAS PLUMBING REQUIREMENTS FOR YOUR SLIDE-IN POWER BURNER	5
ENSURING PROPER COMBUSTION AIR AND COOLING AIR FLOW	5
GAS SUPPLY PLUMBING REQUIREMENTS	5
GAS SUPPLY AND MANIFOLD PRESSURES	5
GAS SUPPLY PRESSURE TESTING	5
SAFE USE & MAINTENANCE OF PROPANE GAS CYLINDERS	7
INSTALLING YOUR FIRE MAGIC POWER BURNER	8
CHECK FUEL ORIFICES FOR PROPER SIZE	8
POSITION THE BURNER FOR OPERATION	8
CONNECT THE GAS SUPPLY TO THE POWER BURNER	8
INSTALL THE FLAME COLLIMATOR	9
REMOVE THE CONTROL PANEL TO CHECK RATING PLATE	9
ADJUST THE AIR SHUTTERS	9
LIGHTING (IGNITION) INSTRUCTIONS	11
CARE & CLEANING	12
CHECKING AND CONVERTING GAS TYPE	13
CHECKING AND CONVERTING THE REGULATOR	13
POWER BURNER NOTES PAGE	14
REPLACING THE IGNITOR BATTERY	15
TROUBLESHOOTING	15
WARRANTY	16

## PRODUCT DATA TABLE

Specification	Value
Counter opening height*	12" (30.5 cm)
Counter opening width*	19" (48.3 cm)
Counter opening depth*	18 3/4" (47.6 cm)
<b>Power Burner</b>	
BTU	20 - 60,000 (5.9 - 17.6 kw)
Natural gas orifice left	#30 (3.261mm)
Natural gas orifice right	#46 (2.055 mm)
Propane gas orifice left	#50 (1.778 mm)
Propane gas orifice right	#1.25

Table 1 - Product Data Table

**\*Note:** If using an insulating liner (part number 3278-50) consult liner instructions for counter cut-out dimensions.

**Note:** The hanger requires 2" (5.1 cm) of countertop on each side and back to support the unit.

# PARTS LIST

Item	Part No.	Description
1.	3278-06	Cover
2.	3545	Grid, porcelain cast iron (black)
or	3545-S	Grid, stainless steel rod
3.	3278-09	Flame collimator (stir fry ring)
4.	3278-01B	Burner assembly, brass
5.	3048-03-2	Spring air shutter (2)
6.	n/a	Air shutter (2) inc. w/ burner
7.	3001-#	Orifices (2) (see table 1)
8.	3199-42	Electrode kit w/ground wire
9.	3278-14	Valve manifold
10.	3016	Control knob, small (inner burner)
11.	3015	Control knob, large (outer burner)
12.	23278-13	Control panel, stainless steel w/mirror finish
13.	3085	Drip tray assembly
14.	3199-43	Igniter module

## TOOLS REQUIRED FOR INSTALLATION:

- #2 (Medium) Phillips screwdriver
- Two medium size adjustable wrenches or pliers
- 3/8" wrench or socket screwdriver
- Pipe joint compound resistant to all gasses

Replacement parts can be ordered from your local Fire Magic dealer.

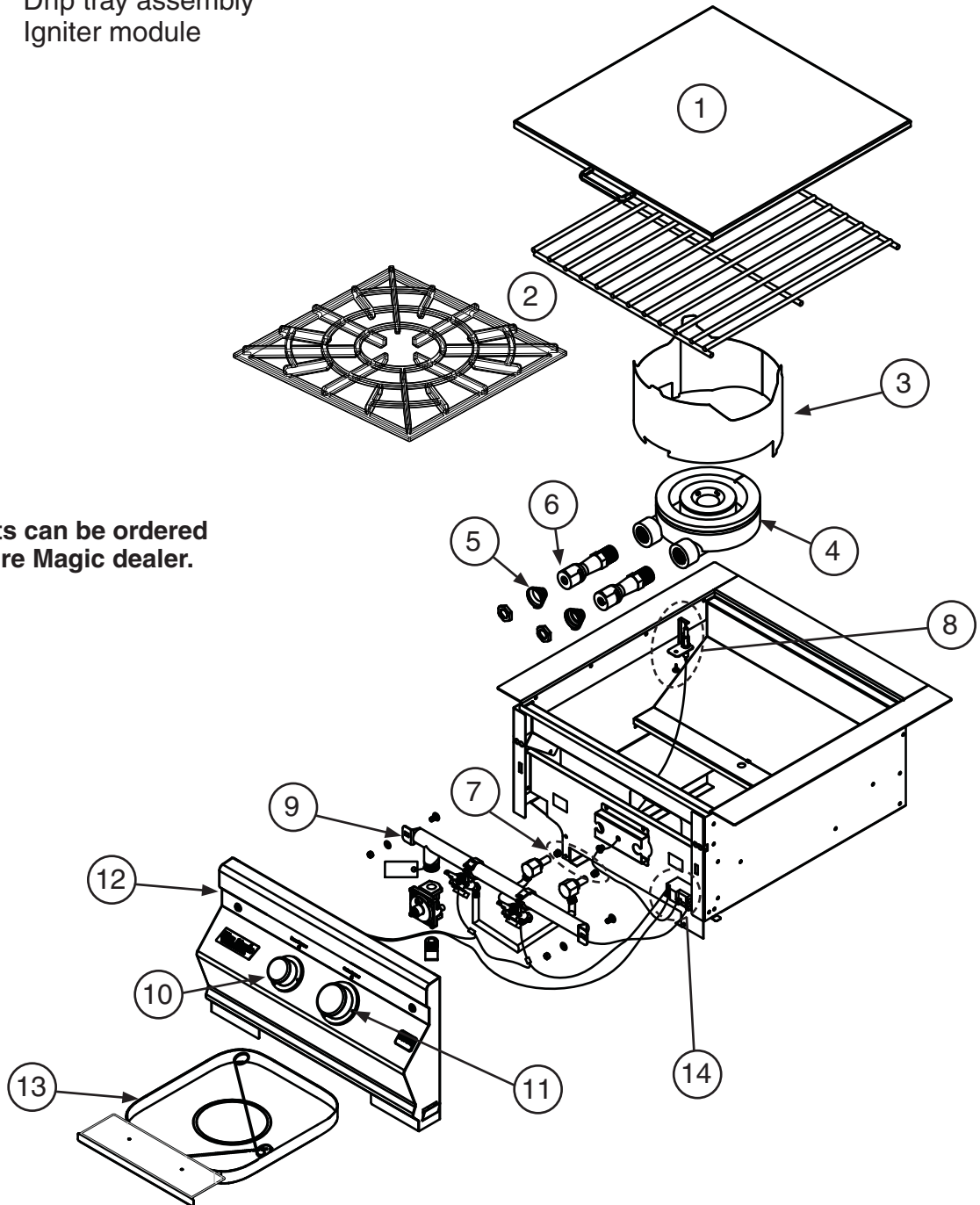

# PLANNING FOR INSTALLATION OF YOUR POWER BURNER

## WHERE TO INSTALL THE POWER BURNER

**IMPORTANT: THIS POWER BURNER IS FOR OUTDOOR USE ONLY.**

### WARNING

The power burner must be installed in masonry or other type of fireproof surround. The unit is not insulated and therefore must be installed or placed with 18" (45.7 cm) of side and back clearance from unprotected combustible materials such as wood, plastic, or stucco with wood framing.

**Do not install this unit under unprotected flammable surfaces. Do not install or use this appliance inside a building, garage, or any other enclosed area. It must not be used in or on recreational vehicles or boats.**

This is a slide-in unit designed to fit into open-front enclosures. Control panel of the unit is removable for gas hookup, servicing and burner adjustment. Control panel must remain removable after you install the unit.

**Important:** The hanger requires 2" (5.1 cm) of countertop on each side and back to support the unit.

**Note:** We recommend you build the enclosure for the power burner 6"-12" (15.2 cm- 30.5 cm) LOWER than your countertop (see Fig. 5-2). This will ensure a safer environment when using tall cooking pots like the turkey fryer, which can hold 40 lbs of hot oil.

**Note:** This unit should be installed so that it can be removed at a later date if factory service is required. Any protrusion into the power burner enclosure may prevent the unit from sliding into place (see GAS SUPPLY PLUMBING REQUIREMENTS).

## ENSURING PROPER COMBUSTION AIR AND COOLING AIR FLOW

You must maintain proper air flow for your Fire Magic power burner to perform as it was designed (Fig. 5-1). If airflow is blocked, overheating and poor combustion will result. Make sure not to block the 1" (2.5 cm) front air inlet along the bottom of the control panel or more than 75% of the support grid surface with pans or griddles.

**Note:** The 1" (2.5 cm) front air space allows access to the drip tray.

## EXHAUST REMOVAL

If installed under a patio roof, the cooking grid area should be fully covered by a chimney and exhaust hood. An exhaust fan with a rating of up to 1,000 CFM (472 liters per second) may be necessary to efficiently remove smoke and other cooking by-products from the covered area. Installation in fully enclosed patio areas is not recommended.

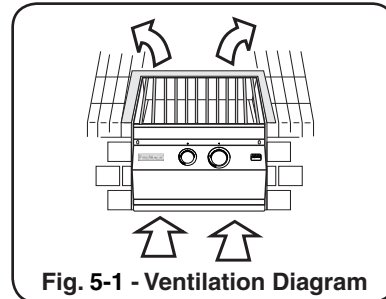

Fig. 5-1 - Ventilation Diagram

# GAS PLUMBING REQUIREMENTS FOR YOUR SLIDE-IN POWER BURNER

## GAS SUPPLY PLUMBING REQUIREMENTS

Rigid 1/2" (1.3 cm) or 3/4" (.75 cm) black steel pipe, or local code approved pipe for temperatures up to 800°F (427°C), is required to conduct the gas supply into the enclosure opening for connection to the unit. **Do not use a rubber hose within the enclosure for the power burner.** Apply only joint compounds that are resistant to all gasses on all male pipe fittings. Make sure to tighten every joint securely.

The gas supply pipe should terminate below the power burner so final connection can be made with an approved flex connector.

Install the gas line stub at least 1 1/2" (3.8 cm) away from the side walls and 1" (2.54 cm) from the back wall, but within 5" (12.7 cm) of the back wall, as illustrated by the shaded area in Fig. 5-2.

**Note:** An external valve (with a removable key) in the gas line is necessary for safety when your power burner is not in use. It also provides for convenient maintenance.

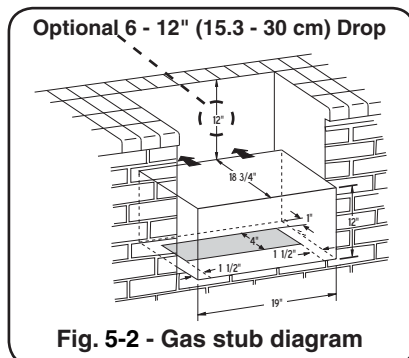

Fig. 5-2 - Gas stub diagram

You will need a C.S.A. approved stainless steel flex connector to bring the gas supply from the gas line stub to the regulator. A 1/2" (1.27 cm) x 36" (91.4 cm) or 24" (61 cm) flex connector with 1/2" (1.27 cm) flare to 1/2" (1.27 cm) pipe adapter on one end, and a 1/2" (1.27 cm) flare female fitting on the other end is suitable for most installations.

**CAUTION:** Use only stainless steel flex connectors that are C.S.A. listed. A rubber or plastic connector will rupture or leak, resulting in an explosion or serious injury if used inside the power burner enclosure.

**Important:** See page 7 for the proper venting of the enclosure.

## GAS SUPPLY AND MANIFOLD PRESSURES

For **natural gas** - Normal 7" (17.8 cm) water column (w.c.), Minimum 3 1/2" (8.9 cm) w.c., Maximum 10 1/2" (26.7 cm) w.c.

For **propane gas** Normal 11" (27.9 cm) (w.c.), Minimum 8" (20.3 cm) (w.c.), Maximum 13" (33 cm).

## GAS SUPPLY PRESSURE TESTING

This appliance and its individual shutoff valves must be disconnected from the gas supply piping system when testing the system at pressures in excess of 1/2 psig (3.5 kpa).

This appliance must be isolated from the gas supply piping system by closing its individual manual shutoff valves during any pressure testing of the gas supply system at pressures up to and including 1/2 psig (3.5 kpa).

# UTILISATION SÛRE ET ENTRETIEN DES CYLINDRES DE GAZ DE PROPANE

## IMPORTANT POUR VOTRE SÛRETÉ

LISEZ ET SUIVEZ TOUS LES AVERTISSEMENTS ÉQUIPÉS DE VOTRE CYLINDRE DE GAZ DE PROPANE.

En actionnant cet appareil avec un cylindre de gaz de propane ON DOIT observer ces instructions et avertissements.

**LE MANQUE DE FAIRE AINSI PEUT AVOIR COMME CONSÉQUENCE UNE INCENDIE OU UNE EXPLOSION SÉRIEUSE.**

### CYLINDRE ET CONDITIONS ET CARACTÉRISTIQUES DE CONNECTEUR

- Des cylindres et les valves de gaz de propane doivent être maintenus en bon état et doivent être remplacés s'il y a des dommages évidents au cylindre ou à la valve.
- Ce gril, une fois utilisé avec un cylindre, devrait être relié à un gallon de la norme 5 (20lb.) cylindre de gaz de propane équipé d'un OPD (remplissez au-dessus du niveau le dispositif d'empêchement). L'OPD a été exigé sur tous les cylindres vendus depuis octobre 1.1998 pour empêcher le remplissage excessif.
- Les dimensions de cylindre devraient être approximativement 12" (30.5cm) de diamètre et 18" (45.7cm) hauts. Des cylindres doivent être construits et marqués selon les caractéristiques pour des cylindres de gaz de propane du département des ETATS-UNIS du transport (D.O.T.) ou le niveau national du Canada, du CAN/CSA-B339, des cylindres, des sphères et des tubes pour le transport des marchandises dangereuses.
- Le cylindre doit inclure un collier pour protéger la valve de cylindre et le circuit d'alimentation de cylindre doit être assuré le retrait de vapeur.
- Le régulateur de pression et l'ensemble de tuyau utilisé doivent assortir les spécifications pour le type I par ANSI Z 21.58-2005/CGA 1.6-2005 (voir la fig. 6-1).
- La valve de cylindre de gaz de propane doit être équipée d'un dispositif d'accouplement de raccordement de cylindre, décrit comme type I dans la norme définie dans le e. de paragraphe ci-dessus. Ce dispositif est généralement décrit comme coupleur rapide de fil de point culminant.
- Si votre cylindre de gaz de propane vient avec une prise de la poussière, placez le bouchon anti-poussière sur la sortie de valve de cylindre toutes les fois que le cylindre n'est pas en service.

### OPÉRATION DE COUPLEUR RAPIDE

**Pour relier le régulateur/hose à l'ajustage de précision de valve de cylindre de gaz de propane:** Serrez l'écrou de main sur le régulateur au-dessus de l'ajustage de précision de fil de point culminant sur la valve de cylindre. Tournez l'écrou de

main dans le sens des aiguilles d'une montre pour engager les fils et pour serrer jusqu'à ce que douillettement. L'utilisation des pinces ou de la clé ne devrait pas être nécessaire. Seulement le propane marqué par cylindres doit être employé.

**Pour débrancher:** Tournez l'écrou de main dans le sens contraire des aiguilles d'une montre jusqu'à isolé (fig. 6-1).

**Important:** Avant d'employer le gril, et ensuite chaque fois que le cylindre est enlevé et rattaché, examinez tous les raccords pour déceler les fuites. Arrêtez les valves de gril et ouvrez la valve principale de cylindre, puis vérifiez les raccords avec de l'eau savonneuse. Réparez toutes les fuites avant d'allumer le gril.

**ATTENTION:** Tournez toujours la valve principale de cylindre de propane au loin après chaque utilisation, et avant de déplacer le gril et le cylindre, ou débrancher l'accouplement. Cette valve doit rester fermée et le cylindre a débranché alors que l'appareil n'est pas en service, quoique l'écoulement de gaz soit arrêté par un dispositif de sûreté quand le coupleur est débranché.

**Inspectez soigneusement** l'ensemble de tuyau chaque fois avant que le gaz soit allumé. Un tuyau criqué ou frangé devrait être remplacé immédiatement.

Si l'appareil est stocké à l'intérieur, le cylindre doit être disconnected et a enlevé. Des cylindres Disconnected doivent être stockés dehors, hors de la portée des enfants, avec les prises de valve filetées étroitement installées, et ne doivent pas être stockés dans un bâtiment, le garage, ou n'importe quel autre secteur inclus.

### POUR VOTRE SÛRETÉ

- Ne stockez pas un cylindre de gaz disponible de propane dessous ou ne vous approchez pas de cet appareil.
- Ne remplissez jamais cylindre au delà de 80 pour cent de plein.
- SI L'INFORMATION DANS "A" ET "B" N'EST PAS SUIVIE EXACTEMENT, UN FEU CAUSANT LA MORT OU DES DOMMAGES SÉRIEUX PEUT SE PRODUIRE.

Fig. 6-1 type coupleur rapide de fil de point culminant d'I

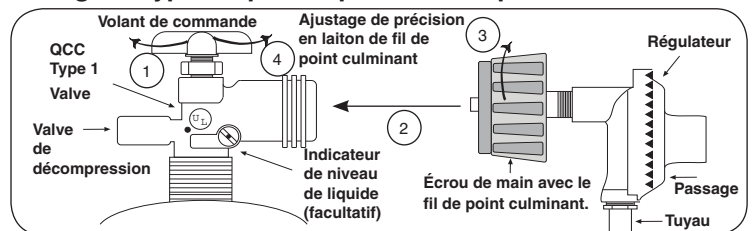

### CONDITIONS DE CLÔTURE

**POUR VOTRE SÛRETÉ,** vous devez fournir les ouvertures suivantes ci-dessous pour le drainage, l'air de recharge, et la ventilation en travers de n'importe quelle zone de stockage exposée à la fuite possible des raccords de gaz, du gril, ou du cylindre de propane:

Un côté de la clôture de cylindre de gaz a laissé complètement ouvert de extérieur OU en fournissant quatre (4) ouvertures de ventilation. Deux ouvertures doivent être au niveau de valve de cylindre (approximativement 16" (40.6 centimètres) au-dessus du plancher) et sur les murs opposés de la clôture. Deux ouvertures supplémentaires doivent être au niveau de plancher des côtés opposés de la clôture. Les ouvertures de niveau de plancher doivent commencer au plancher et se prolongeront pas plus haut que 5" (12.7 centimètre) au-dessus du plancher. Chaque ouverture doit avoir un minimum de 10 pouces carrés (64.5 cm<sup>2</sup>) du secteur libre. Pour réaliser la ventilation appropriée, vous pouvez forer une série de trous, omettez le coulis des joints de maçonnerie, ou remplacez une brique avec un écran de tissu de matériel. Si le plancher dans le coffret est augmenté et l'espace sous le coffret est ouvert d'extérieur, les ouvertures inférieures de ventilation peuvent être dans le plancher.

# SAFE USE & MAINTENANCE OF PROPANE GAS CYLINDERS

## IMPORTANT FOR YOUR SAFETY

### READ AND FOLLOW ALL WARNINGS PROVIDED WITH THE PROPANE-GAS CYLINDER.

When operating this appliance with a propane-gas cylinder, these instructions and warnings **MUST** be observed.

**FAILURE TO DO SO MAY RESULT IN A SERIOUS FIRE OR EXPLOSION.**

## CYLINDER/CONNECTOR REQUIREMENTS

- Propane-gas cylinders, valves, and hoses must be maintained in good condition and must be replaced if there is visible damage to either the cylinder or valve. If the hose is cut or shows excessive abrasion or wear, it must be replaced before using the gas appliance (see e.).
- This unit, when used with a cylinder, should be connected to a standard 5-gallon (20 lb.) propane-gas cylinder equipped with an OPD (Overfill Prevention Device). The OPD has been required on all cylinders sold since October 1, 1998, to prevent overfilling.
- Cylinder dimensions should be approximately 12" (30.5 cm) in diameter and 18" (45.7 cm) high. Cylinders must be constructed and marked in accordance with the *Specifications for Propane Gas Cylinders of the U.S. Department of Transportation (D.O.T.)* or the National Standard of Canada, *CAN/CSA-B339, Cylinders, Spheres, and Tubes for Transportation of Dangerous Goods*.
- The cylinder used must include a collar to protect the cylinder valve, and the cylinder supply system must be arranged for vapor withdrawal.
- The pressure regulator and hose assembly used must match the specification for Type I by *ANSI Z 21.58-2005/CGA 1.6-2005* (see Fig. 7-1).
- The propane-gas cylinder valve must be equipped with a cylinder connection coupling device, described as Type I in the standard defined in paragraph e. above. This device is commonly described as an Acme thread quick coupler.
- If the propane-gas cylinder comes with a dust plug, place the dust cap on the cylinder valve outlet whenever the cylinder is not in use.

## QUICK COUPLER OPERATION

**To connect the regulator/hose assembly to the propane-gas cylinder valve fitting:** Press the hand nut on the regulator over the Acme thread fitting on the cylinder valve. Turn the hand nut clockwise to engage the threads and tighten until snug.

## ENCLOSURE REQUIREMENTS

**FOR YOUR SAFETY, you must provide the openings listed below for drainage, replacement air, and cross-ventilation of any storage area exposed to possible leakage from gas connections, the unit, or propane cylinders:**

One side of the gas cylinder enclosure left completely open to the outside **OR** by providing four (4) ventilation openings. Two (2) openings are to be at the cylinder valve level (approx. 16" [40.6 cm] above the floor) and on opposite walls of the enclosure. Two (2) more openings must be at the floor level on opposite sides of the enclosure. The floor-level openings must start at the floor and shall extend no higher than 5" (12.7 cm) above the floor. Each opening must have a minimum of 10 sq. in. (64.5 cm<sup>2</sup>) of free area. To achieve the proper ventilation, you may drill a series of holes, omit the grout from masonry joints, or replace a brick with a hardware cloth screen. If the floor in the cabinet is raised and the space beneath the cabinet is open to the outside, the lower ventilation openings may be in the floor.

Consult your gas supplier for ventilation and regulator requirements when connecting to a household propane supply.

The use of pliers or a wrench should not be necessary. Only cylinders marked "propane" may be used.

**To disconnect:** Turn the hand nut counterclockwise until detached (Fig. 7-1).

**Important:** Before using the unit, and after each time the cylinder is removed and reattached, check the hose for wear (see a.) and check all connections for leaks. Turn off the unit valves and open the main cylinder valve, then check connections with soapy water. Repair any leaks before lighting the unit.

**CAUTION:** Always turn the propane cylinder main valve off after each use, and before moving the unit and cylinder or disconnecting the coupling. This valve must remain closed and the cylinder disconnected while the appliance is not in use, even though the gas flow is stopped by a safety feature when the coupler is disconnected.

**Carefully** inspect the hose assembly each time before the gas is turned on. A cracked or frayed hose should be replaced immediately.

If the appliance is stored indoors, the cylinder must be disconnected and removed. Disconnected cylinders must be stored outdoors, out of the reach of children, with threaded valve plugs tightly installed, and must not be stored in a building, garage, or any other enclosed area.

## FOR YOUR SAFETY

- DO NOT store a spare propane-gas cylinder under or near this appliance.
- NEVER fill the cylinder beyond 80-percent full.
- IF THE INFORMATION IN a. AND b. IS NOT FOLLOWED EXACTLY, A FIRE CAUSING DEATH OR SERIOUS INJURY MAY OCCUR.

Fig. 7-1 Type I Acme thread quick coupler

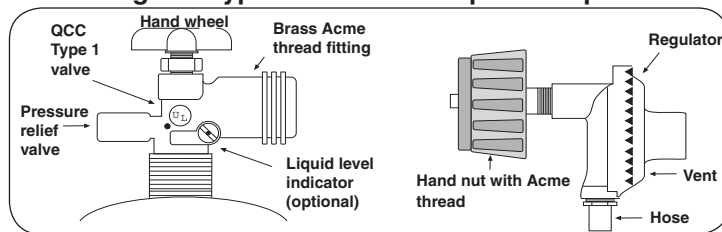

# INSTALLING YOUR FIRE MAGIC POWER BURNER

Perform the following checks before installing your power burner:

## CHECK FUEL ORIFICES FOR PROPER SIZE

1. Your Fire Magic power burner is equipped with fuel orifices for natural gas, unless otherwise indicated. To change the gas type, you must install different orifices to avoid hazardous overheating. (Refer to Table 1 for the proper orifice size)

**IMPORTANT:** When converting orifices for different gas type, the regulator must also be converted for the new gas type. Reference the REMOVE THE CONTROL PANEL and CONVERTING THE REGULATOR sections.

2. Remove the cooking grid. Grip the flame collimator and remove it by compressing the ring slightly front to back and lifting the compressed end upward. (Reference Fig. 9-1.)
3. Check the orifice size by lifting the burner up and out of the locator hole and pulling it away from the orifices. The orifice size is stamped on the orifice face. Be sure not to lose the air shutter or air shutter spring which may become detached when the burner is removed.

## POSITION THE BURNER FOR OPERATION

1. After checking orifice size install the air shutter spring and the air shutter over the orifice holder fitting, between the burner and the heat shield, in the order and position shown in Fig. 8-1.
2. Carefully place the burner stud back in the locator hole so that the brass orifice and orifice holder fittings project into the burner air venturi. When the burner stud fits in the locator hole the orifice is in alignment.

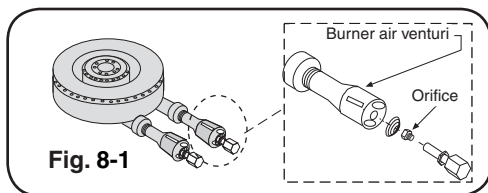

## CONNECT THE GAS SUPPLY TO THE POWER BURNER

1. Make sure that your gas supply is turned OFF. Then connect the 1/2" pipe adapter fitting supplied with the stainless steel flex connector to the gas supply stub. Use pipe joint compound that is resistant to all gasses on the male pipe fitting and tighten securely. Do not use pipe joint compound on flare fittings.

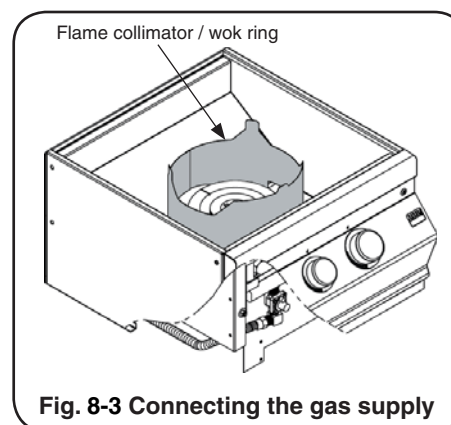
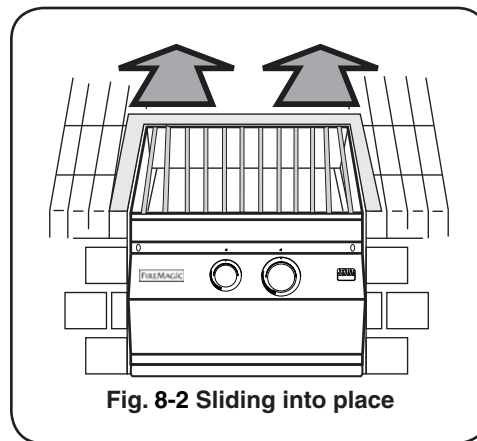

2. Slide your power burner into place, making sure not to pinch or kink the gas connector (Fig. 8-2).
3. Bring the flex connector along the left side of the power burner to the front of the unit and the regulator inlet flare fitting. Use the connector support bracket to hold the flex connector up away from the drip tray and keep front vent clear (Fig. 8-3).
4. Connect the flex connector to the flare fitting on the regulator. Support the regulator inlet fitting with a wrench to avoid applying excessive torque to the manifold assembly while tightening this connection securely. **DO NOT** use pipe compound on flare fittings.
5. Make sure the power burner valves are in the OFF position. Turn the gas supply on. Then carefully check all gas connections for leaks with a brush and soapy water before lighting.

**WARNING:** Never use a match or open flame to test for leaks.

# INSTALLING YOUR FIRE MAGIC POWER BURNER (Cont.)

## INSTALL THE FLAME COLLIMATOR

1. Place the flame collimator over the burner with the tabs and cutouts resting on the inner liner shelf, as shown in Fig. 9-1. Flex the front of the collimator towards the burner until the cut outs fit down around the collimator support. This will lock your collimator into place. The flame collimator acts as a barrier for windy conditions and creates higher BTU concentration in the cooking grid.
2. When using a wok for stir fry cooking, remove the grid and the wok will be supported by the collimator.

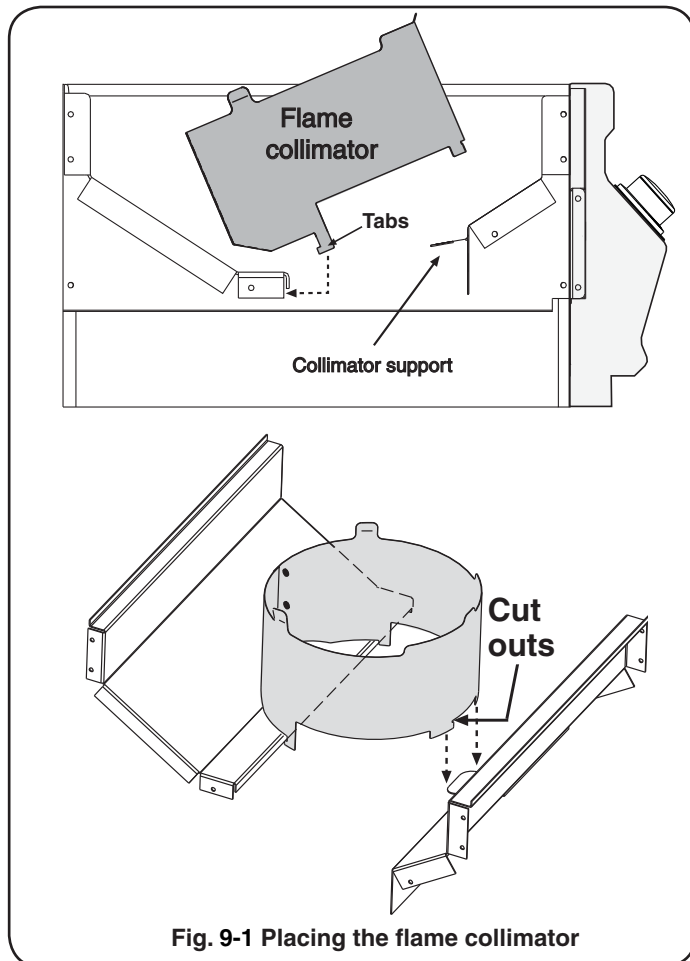

## REMOVE THE CONTROL PANEL TO CHECK RATING PLATE

The control panel may be removed to access the rating plate and check for the gas type of your power burner.

1. Make sure the burner valves are in the OFF position. Carefully pull the control knobs from their stems. Use the Phillips screwdriver to remove the mounting screws. Make sure to retain the screws and finish washers to reattach the control panel.

**Important:** Prior to fully removing the control panel, you must disconnect the battery holder assembly wires that are located behind the control panel.

3. Carefully lift the control panel away from the frame.
4. Check the rating plate for gas type.
5. Replace the control panel, being sure to reconnect the battery holder assembly wires.

**Important:** Test the electrode for spark before securing the control panel to the frame. Place the control panel on the frame so the front lip of the control panel covers the lip on the frame.

6. Secure the control panel to the frame with the screws and washers. Replace the control knobs.

## ADJUST THE AIR SHUTTERS

Power burner air shutter(s) are located on the necks of the power burner as shown in Fig. 9-2.

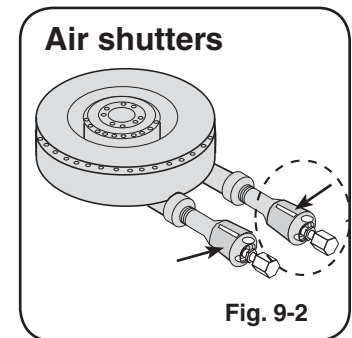

**CAUTION: DO NOT handle a hot burner without adequate hand protection.**

To adjust the air shutters:

1. See step 2 under the CHECK FUEL ORIFICES FOR PROPER SIZE section.
2. Lift the back of the burner upward so that the burner stud in the bottom back clears the locator hole in the burner rest.
3. Move the burner back away from the front of the power burner while continuing to lift the back upward so that it clears the rear firewall.
4. Turn the shutter to the desired opening size and replace the burner to test the effect on the flame (see LIGHTING INSTRUCTIONS).

**Burner flames should burn evenly (mostly blue). A proper flame pattern will ensure safe operation and optimal performance.**

# ALLUMAGE DES INSTRUCTIONS (D'ALLUMAGE)

Lisez toutes les instructions avant l'allumage, et suivez ces instructions chaque fois vous lumière le unité.

## ÉCLAIRAGE ÉLECTRONIQUE

**Note:** L'éclairage électronique exige une batterie installée de 9 volts avec une bonne charge.

1. Ouvrez les couvercles ou enlevez les couvertures des brûleurs pour être Lit.
2. Tournez tous les boutons de commande de gaz à leurs positions de repos.
3. Allumez le gaz à sa source.

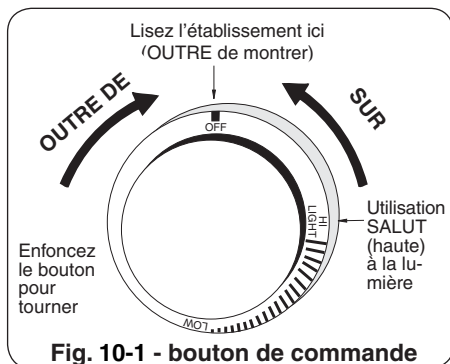

Fig. 10-1 - bouton de commande

**Note:** N'ouvrez pas plus d'une valve à la fois pour l'éclairage électronique ou manuel.

4. Diminuez le bouton de commande désiré, et tout en pressant le tour il dans le sens contraire des aiguilles d'une montre dans la position LÉGÈRE de HI. Une fois que le brûleur s'allume, libérez le bouton de commande.

**ATTENTION :** Si un brûleur ne s'allume pas dans cinq (5) secondes d'allumer le bouton de commande, enfoncez le bouton et tournez-le à la position de repos. ATTENDEZ CINQ (5) MINUTES avant de répéter l'étape 4. Si vous sentez le gaz, suivez les instructions sur la couverture de ce manuel. Si les brûleurs ne s'allument toujours pas après que plusieurs tentatives, se rapportent aux instructions pour l'éclairage manuel.

5. Répétez l'étape 4 pour que chaque brûleur additionnel soit Lit.

## ÉCLAIRAGE MANUEL

**ATTENTION:** Attendez toujours cinq minutes le gaz pour se dégager après que n'importe quelle tentative non réussie d'éclairage.

**AVERTISSEMENT:** Ne mettez pas la main directement au-dessus du brûleur en s'allumant mais au loin au côté comme montré (Fig. 10-2).

1. Suivez les étapes 1 à 3 (à gauche).
- 2a. Insérez un allumeur brûlant de butane de long-baril, une allumette brûlante de long-tige, ou une allumette brûlante tenue par un support de prolongation de fil par les grilles à cuire au brûleur désiré à allumer (Fig. 10-2). Avec la flamme toujours à côté du brûleur, diminuez le bouton de commande de correspondance (bouton externe de droite de brûleur, brûleur intérieur laissés le bouton), et tout en pressant le tour il dans le sens contraire des aiguilles d'une montre dans la position LÉGÈRE de HI. Enlevez l'allumeur ou assortissez quand le brûleur s'allume, et libérez le bouton de commande.
- 2b. Pour allumer manuellement le deuxième brûleur, après que l'étape 2a ait été suivie, diminuez le bouton de commande de correspondance, et tout en pressant le tour il dans le sens contraire des aiguilles d'une montre dans la position LÉGÈRE de HI. Le deuxième brûleur s'allumera de la flamme du brûleur déjà allumé. Libérez le bouton de commande.
3. Si le brûleur ne s'allume pas, tournez immédiatement le bouton de commande de brûleur à la position de repos. ATTENDEZ CINQ MINUTES avant de répéter les étapes 2 et 3 des INSTRUCTIONS MANUELLES D'ÉCLAIRAGE.

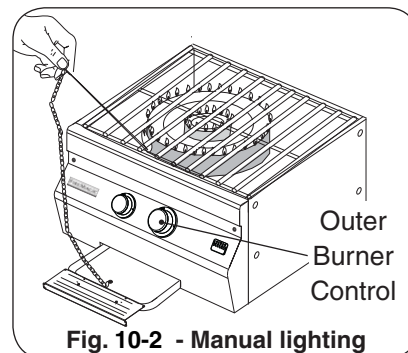

Fig. 10-2 - Manual lighting

## ARRÊT DU UNITÉ

Pour couper le unité, diminuez chaque bouton de commande de valve et, et tout en pressant tour il dans le sens des aiguilles d'une montre à la position de repos.

Fermez toujours la valve de la fourniture de gaz après chaque utilisation du unité.

## EN EMPLOYANT UN RÉSERVOIR DE PROPANE PORTATIF

Des réservoirs de propane sont équipés d'un dispositif d'arrêt de sûreté qui peut ne pas causer le bas ou aucunes pression de gaz/flamme aux brûleurs si le fonctionnement et l'allumage des instructions ne sont pas suivis exactement (voir la note importante dans la section de dépannage pour plus de détails.)

# LIGHTING (IGNITION) INSTRUCTIONS

Read all instructions before lighting, and follow these instructions each time you light the unit.

## ELECTRONIC LIGHTING

**Note:** Electronic lighting requires an installed 9-volt battery with a good charge.

1. Open lid(s) or remove cover(s) from burner(s) to be lit.
2. Turn all gas control knob(s) to their **OFF** position(s).
3. Turn on the gas at its source.

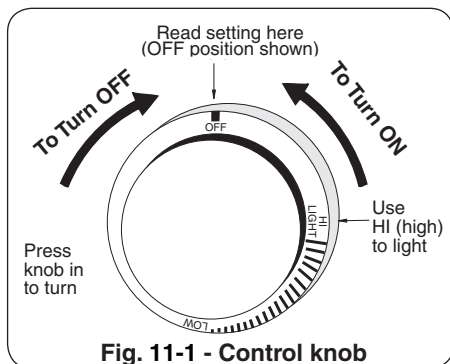

Fig. 11-1 - Control knob

**Note:** DO NOT turn on more than one valve at a time for either electronic or manual lighting.

4. Depress the desired control knob, and while pressing turn it counterclockwise to the **HI LIGHT** position. Once the burner lights, release the control knob.

**CAUTION:** If a burner does not light within five (5) seconds of turning on the control knob, depress the knob and turn it to the **OFF** position. **WAIT FIVE (5) MINUTES** before repeating step 4. If you smell gas, follow the instructions on the cover of this manual. If the burners still do not light after several attempts, refer to the instructions for manual lighting.

5. Repeat step 4 for each additional burner to be lit.

## WHEN USING A PORTABLE PROPANE TANK

Propane tanks are equipped with a safety shutdown device that may cause low or no gas pressure/flame at the burners if operating and lighting instructions are not followed exactly (See important note in the TROUBLESHOOTING section for more details.)

## MANUAL LIGHTING

**CAUTION:** Always wait five minutes for gas to clear after any unsuccessful lighting attempt.

**WARNING:** DO NOT put hand directly above the burner when lighting but off to the side as shown (Fig. 11-2).

1. Follow steps 1 through 3 (left).
- 2a. Insert either a burning long-barrel butane lighter, a burning long-stem match, or a burning match held by a wire extension holder through the cooking grids to the desired burner to be lit (Fig. 11-2). **With the flame still next to the burner, depress the corresponding control knob (outer burner-right knob, inner burner-left knob), and while pressing turn it counterclockwise to the HI LIGHT position.** Remove the lighter or match when the burner lights, and release the control knob.
- 2b. **To manually light the second burner, after step 2a has been followed,** depress the corresponding control knob, and while pressing turn it counterclockwise to the **HI LIGHT** position. The second burner will light from the flame of the already lit burner. Release the control knob.
3. If the burner does not light, **IMMEDIATELY** turn the burner control knob to the **OFF** position. **WAIT FIVE MINUTES** before repeating steps 2 and 3 of the MANUAL LIGHTING INSTRUCTIONS.

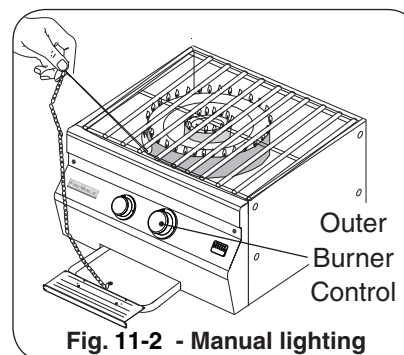

Fig. 11-2 - Manual lighting

## SHUTTING OFF THE UNIT

To shut off the unit, depress each valve control knob and, while pressing turn it clockwise to the **OFF** position.

Always close the valve from the gas supply after each use of the unit.

### CARE AND CLEANING

APPLIANCE MUST BE COMPLETELY COOL WHEN CLEANING. DO NOT SPRAY ANY CLEANER OR LIQUIDS ON THE APPLIANCE WHEN HOT.

Stainless steel surfaces when exposed to temperatures produced by the grilling process will change color. The stainless steel will change color from silver to brown and blue. This can be removed by using Fire Magic Stainless Steel Cleaner (3581-1).

Clean your appliance by first using Fire Magic Barbecue and Grill Cleaner (part #3580-1) to remove grease and dirt. Always wipe with the grain (See Fig. 12-1). Next, use Fire Magic Stainless Steel Cleaner (3581-1) to restore the stainless steel color (Note: not for mirror finish). Finish by wiping your appliance down using Fire Magic Polish Wipes (3586-1). **To clean the mirror panel (if applicable), use a quality brand glass cleaner only, not any of the cleaners mentioned above.**

Clean your appliance at least once a month.

If your appliance is installed in a seaside (salt air) or poolside (chlorine) location, it will be more susceptible to corrosion and must be maintained/cleaned more frequently. Do not store chemicals (such as chlorine or fertilizer) near your stainless steel appliance.

Due to the nature of stainless steel, surface iron oxide deposits may appear. Do not be alarmed – these deposits are removable with stainless-steel cleaner through prompt and periodic maintenance. If not attended to promptly, permanent pitting may occur.

Check and clean the burner ports and burner carry-over slits for blockage at least annually by removing the burner (see orifice changing instructions) and visually inspecting the burner inlet for insects and nests. A clogged burner can lead to a fire in the bottom of the appliance. (For Fire Magic grills use Maintenance Kit part #MK-1.)

The inside of the appliance may be cleaned periodically with oven cleaner if desired. Follow the oven cleaner instructions for proper use.

Be careful not to get oven cleaner on the outside surface of the appliance as it can permanently damage the finish.

By following these recommendations, you will enjoy the beauty and convenience of your appliance for many years to come.



Fig. 12-1 - Wipe with grain

### PROTECTING YOUR APPLIANCE FROM THE WEATHER

An optional heavy-duty cover will protect your appliance's finish and protect your investment. The water repellent cover will protect your appliance from the weather. Always cover your appliance when not in use. (Allow to cool before covering.)

Please specify the model number and serial number of your appliance when ordering a cover.

### IMPORTANT

**IN THE EVENT OF A GREASE FIRE, IMMEDIATELY SHUT OFF THE MAIN GAS VALVE TO THE GRILL. KEEP THE LID OPEN AND ALLOW THE FIRE TO EXTINGUISH ITSELF. A THOROUGH INSPECTION BY A TRAINED SERVICE TECHNICIAN SHOULD BE CONDUCTED BEFORE FUTURE USE OF YOUR GRILL. THE SERVICE TECHNICIAN WILL CHECK THE SYSTEM FOR GAS LEAKS AND WILL CHECK ALL ELECTRICAL WIRING FOR DAMAGE. ALL GAS LEAKS AND WIRING MUST BE REPAIRED PRIOR TO FUTURE USE.**

## CHECKING AND CONVERTING GAS TYPE

This unit comes from the factory configured for one type of gas, as marked on the label behind the control panel.

**Converting this unit to burn a different type of gas requires a conversion kit from the factory. The professional installer who converts this unit to burn a different gas must perform the following functions:**

1. Change brass gas orifices (included at original shipping) on each burner to match the new gas type (see PRODUCT DATA TABLE, Table 1).
2. Switch the convertible gas regulator (included at original shipping, located behind the control panel) to match the new gas type (see below).
3. Plumb the unit to the new gas supply.
4. Apply a new label behind the control panel, indicating the new gas the unit will burn (included with conversion kit).

### **WARNING**

**HAZARDOUS OVERHEATING WILL OCCUR IF A NATURAL-GAS ORIFICE IS USED WITH PROPANE GAS. IF YOU ARE NOT SURE IF THE CORRECT ORIFICES ARE INSTALLED, OR IF AN ORIFICE CHANGE IS NECESSARY, REFER TO THE FOLLOWING INSTRUCTIONS.**

**CAUTION:** Make sure the unit is at a safe temperature and isolated from gas and electrical supplies before beginning the tasks outlined below.

**Note:** The cooler the unit, the greater the tolerances between the stainless-steel parts, and therefore the easier to disassemble and reassemble parts of the unit.

**CAUTION:** For your safety, exercise caution and use adequate hand protection (such as gloves) when handling potentially sharp sheet-metal parts.

## CHECKING AND CONVERTING THE REGULATOR

Regulator: note the cap on top

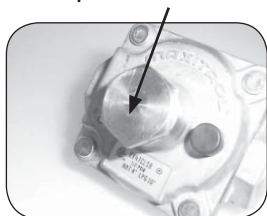

**Note:** Each end of the plastic converter is engraved with either the letters "NAT" or "L.P." (propane) for the respective gasses. When the converter is in the cap and the cap is held uppermost, the letters seen indicate the gas that the regulator is set up for.

To convert the regulator from one gas to another, follow steps 1-4.



**STEP 1:** Unscrew and remove the cap from the regulator, extracting the converter.



Read gas type here

**STEP 3:** Turn the converter around and replace it carefully, into the center of the cap (it will snap into place). Check that you can read the type of gas the unit is set for.



**STEP 2:** Remove the converter (the plastic stalk) by carefully pulling it away from the center of the cap (it will snap out of its seating).

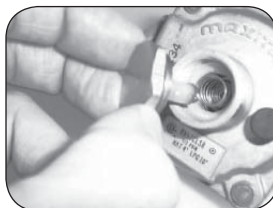

**STEP 4:** Replace the unit into the regulator and screw down until snug.

### **WARNING**

THIS APPLIANCE REGULATOR IS RATED FOR 1/2 PSI MAXIMUM. IF YOUR GAS SUPPLY IS GREATER THAN 1/2 PSI, AN ADDITIONAL REGULATOR MUST BE INSTALLED TO REDUCE THE INPUT PRESSURE TO THE UNIT TO 1/2 PSI OR LESS. SEE GAS-SUPPLY REQUIREMENTS SECTION FOR PROPER GAS-SUPPLY PRESSURE.

## POWER BURNER NOTES PAGE

Please use this page to record any information about your power burner that you may want to have at hand.

## REPLACING THE IGNITOR BATTERY

To replace the 9V battery powering the ignitors, pull out the battery holder located on the outside of the control panel. It may be necessary to lift the drawer up slightly before it will pull out. Disconnect the battery from the connector and replace it connecting the new battery and closing the drawer (see Fig. 15-1).

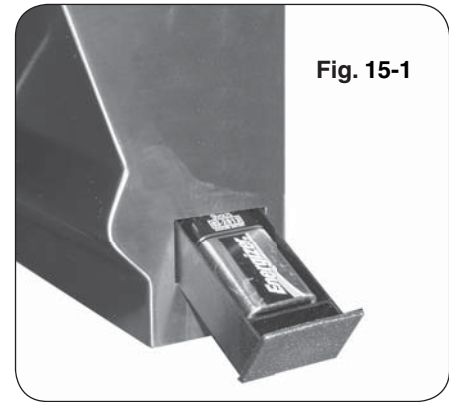

## TROUBLESHOOTING

If you have trouble with the unit, please use this list to identify the problem. By trying one or more of the solutions to the possible cause, you should be able to solve the problem. If this list does not cover your present problem, or if you have other technical difficulties with the unit, please contact your local dealer.

PROBLEM	POSSIBLE CAUSE	CORRECTION
<b>Ignition system failure</b>	1) Improper air shutter adjustment	1) Adjust air shutters.
	2) Ignition wire disconnected	2) Replug wires into generator.
	3) Low gas pressure	3) Adjust or replace battery.
	4) Dead battery	4) Replace battery.
<b>Insufficient heat</b>	1) Improper air shutter adjustment	1) Adjust air shutters.
	2) Using propane orifice for natural gas	2) Change orifices.
	3) Low gas pressure/flame (natural)	3) Have gas company check the operating pressure at the unit.
	4) Low gas pressure/flame (propane)	4) Refill propane tank, or reset propane tank safety*: Shut off all valves (including propane tank) and follow lighting instructions exactly.
<b>Uneven heating</b>	1) Burner ports partially blocked by debris	1) Remove burners and clean out ports.
	2) Small spiders or insects in burner	2) Inspect burners for spider webs or other debris that may block gas flow.
<b>Burner goes out on LOW</b>	1) Valve "Low" setting needs adjustment	1) Light burner on HIGH, immediately turn to LOW setting. Remove knob from valve and using a small flat screwdriver, slowly turn the adjustment screw in the stem, a little at a time (30° to 45°), in either direction, until the flame is approximately 1/4" in height from burner ports.

**Note:** \*Propane tanks are equipped with a safety shutdown device that may cause low or no gas/flame at the burners if operating and lighting instructions are not followed exactly. If you suspect the propane tank safety shutoff is in effect, shut off all burner control valves and the propane tank valve. Then read and follow the LIGHTING INSTRUCTIONS exactly. Lighting instructions are located in the owner's manual. If the problem persists, continue troubleshooting, or contact your local dealer or distributor for assistance.

# WARRANTY

**LIFETIME WARRANTY** - Fire Magic® cast stainless-steel burners, stainless-steel rod cooking grids, and stainless-steel housings are warranted for as long as you own your Fire Magic® grill.

**FIFTEEN-YEAR WARRANTY** - Fire Magic® cast brass burners, brass valves, backburner assemblies (except ignition parts), and manifold assemblies are warranted for 15 years from the date of purchase of your Fire Magic® grill.

**THREE-YEAR WARRANTY** - Fire Magic® sideburners and all other Fire Magic® grill components (except ignition and electronic parts) are warranted for three (3) years from the date of purchase of your Fire Magic® grill.

Fire Magic® ignition systems (excluding batteries), electronic components (including lights and thermometers), and accessories are warranted for one (1) year from date of purchase.

## PLEASE KEEP A COPY OF YOUR SALES SLIP FOR PROOF OF PURCHASE

This warranty applies to the original purchaser and to single family residential use only. It commences from date of purchase, and is valid only with proof of purchase.

This warranty does not cover parts becoming defective through misuse, accidental damage, electrical damage, improper handling, storage, and/or installation. Product must be installed (and gas must be connected) as specified in the instructions or operator's manual, by a **qualified professional installer**. Accessories, parts, valves, remotes, etc., when used must be Peterson Co. product.

This warranty **does not** apply to rust, corrosion, oxidation, or discoloration, unless the affected component becomes inoperable. It **does not** cover labor or labor-related charges.

This warranty specifically excludes liability for **indirect, incidental**, or consequential damages. Some states do not allow the exclusion or limitation of incidental or consequential damages, so the above exclusion may not apply to you. This warranty gives you specified legal rights, and you may have other rights that may vary from state to state.

For additional information regarding this warranty, or to place a warranty claim, contact the R.H. Peterson dealer where the product was purchased.

**TO REGISTER YOUR PRODUCT ONLINE GO TO: [WWW.RHPETERSON.COM](http://WWW.RHPETERSON.COM),  
AND CLICK ON PRODUCT REGISTRATION. THANK YOU FOR YOUR PURCHASE.**

<b>Quality Check</b>			<b>Date:</b> _____		
<b>Burner Orifices</b>	<b>Nat.</b>	<b>L.P.</b>	<b>Leak Test:</b> _____	<b>Model#:</b>	_____
<b>Main:</b>	_____	_____	<b>Burn Test:</b> _____	<b>Serial#:</b>	_____
<b>Other:</b>	_____	_____	<b>Gas Type:</b> <u>Nat. / L.P.</u>	<b>Air Shutter:</b>	_____
				<b>Inspector:</b>	_____